

CR1632

3V Lithium Battery
Swiss Made

Technical Data Sheet

Specifications

Chemical System	Li / MnO ₂
Nominal Voltage	3 V
Rated Capacity	137 mAh
Standard Discharge Current	0.2 mA
Max. Cont. Discharge Current**	1.5 mA
Average Weight	~ 1.8 g
Operating Temperature*	-40 - +85 °C
Self Discharge at 23°C	< 1% / year

Dimensions

(According to IEC 60086)

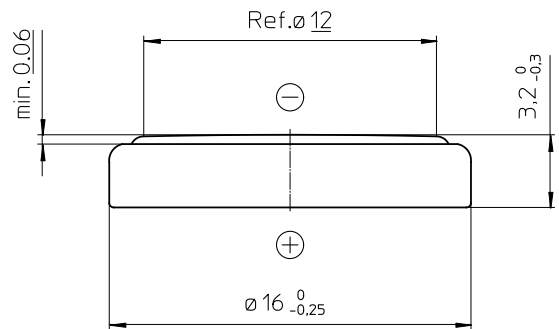

Performance

Discharge performance at 23°C

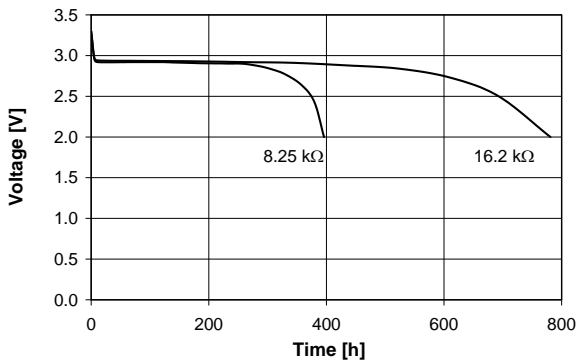

Discharge performance at 23°C

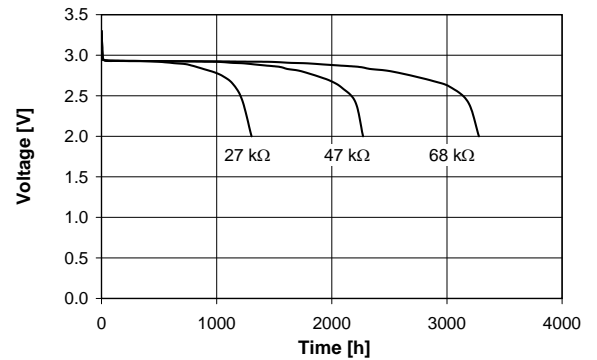

Temperature performance Load 16.2kΩ

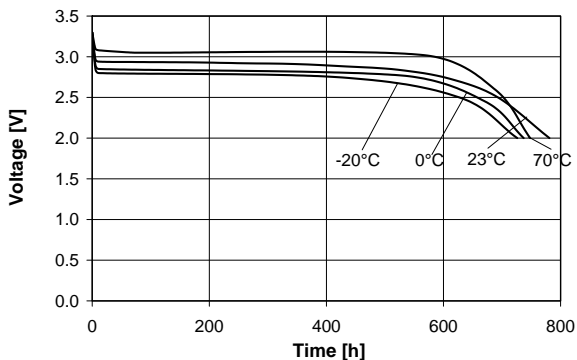

Cell capacity at various loads

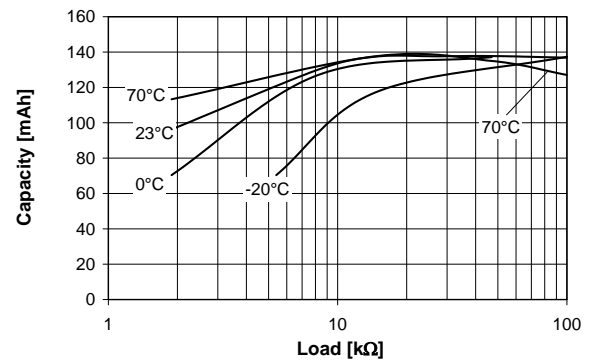

*In applications where the battery is exposed to temperatures above 70 °C, please contact Renata for consultancy.
**Average discharge current for a yield of 70% of the nominal capacity with cut-off voltage of 2.0V at 23°C.